

# tesla pro

The hot melt application head for the tiniest dots at the highest machine speeds  
Efficient, durable, no compressed air

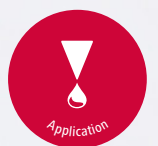

Let's stick together

# tesla pro – the innovative highspeed application head for hot melt application

The heart of the tesla pro system is the electromagnetic application head for hot melt application. The use of tesla pro leads to a marked reduction in production costs: in the short term by eliminating the need for extremely expensive compressed air, and in the medium term through the very long service life of the application head of up to 1 billion switching operations. It is controlled via the Baumer hhs controller.

## Improving health and safety

Elimination of the compressed-air supply greatly improves industrial safety. The noise level on the machine is considerably lower, compared to the use of electropneumatic application heads. The head is very largely insulated, minimising the risk of operators burning themselves. The integrated temperature switch automatically shuts off the head in the event of overheating, switching it back on when the permissible temperature is reached again. That improves the safety of the operators and reliability of the machine and your components.

## Combining speed and quality

tesla pro permits extremely fast switching cycles of 600 Hz. Perfect dot application is guaranteed, even at the highest machine speeds. The system demonstrates excellent cut-off characteristics, even during pro, intermittent gluing.

## Revolutionary technology for time-proven quality

tesla pro is a synthesis of time-proven Baumer hhs quality in hot melt application and innovative engineering, tailored to the special demands in end-of-line packaging.

## Glue application: dots and beads

Product-related glue application patterns can be programmed at will with the Xpect controller and the electromagnetic tesla hot melt application head.

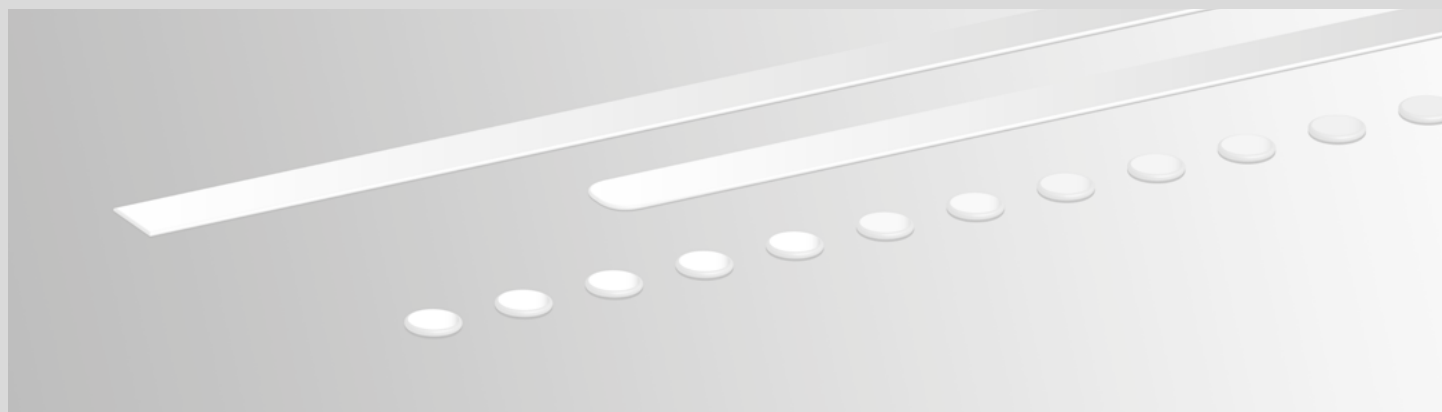

Glue application: dot and bead mode

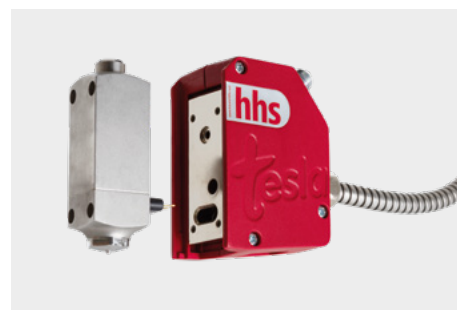
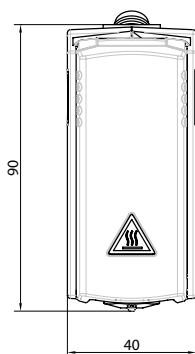
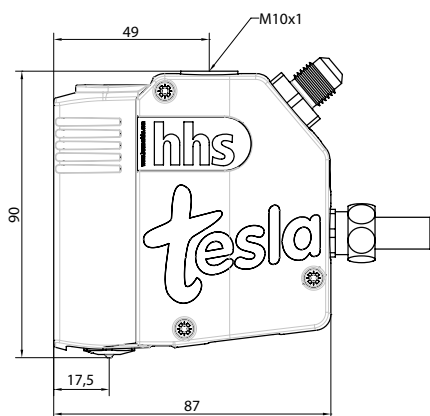

Application head with plug-in module

## Technical Data

Model	Temperature range	Operating voltage, heating	Temperature monitor	Switching frequency	Connection	Hose connections	Adhesive pressure	Adhesive viscosity	Noise emission	Mounting
tesla pro	0...200°C	Controlled by Xmelt	Pt 100	600 Hz	15-pin plug	1/2" UNF	80 bar	max. 5.000 m Pa.s	65 dB	Top cover plate with M10x1 thread

# The system components for hot melt application



Hose with integrated overtemperature cut-out and IP54 protection

## Heated hot melt hoses

The highly flexible Xmelt hot melt hoses transport liquid hot melt to the application head at the right temperature and under pressure. In conjunction with Baumer hhs hot melt units and application heads, Xmelt hoses can control the temperature of the hot melt at various levels from the tank to the application head. At no point is the adhesive overheated, ruling out the risk of carbonisation. Special Baumer hhs electronics enable Xmelt application heads and Xmelt hoses to communicate with the central Xmelt hot melt unit. The seamless integration of the hose into the system means that the adhesive is transported gently, at the ideal pressure and the perfect temperature.

## Technical Data

Operating voltage	Temperature sensor	Max. operating temperature	Max. operating pressure	Hose insulation	Outer protection	Outside diameter	Ambient temperature	Relative humidity
1N-230 ±10% 50/60Hz	Pt100	200°C	80 bar	Silicone foam	Polyamide fabric	45 mm	0...+50°C	<90%, non-condensing

The following hose lengths can be supplied as standard (special lengths upon request): Ø 45 mm: 600 mm, 1800 mm, 2400 mm, 3000 mm, 4000 mm, 5000 mm, 6000 mm  
Ø 1.77": 23.6"; 47.24"; 70.86"; 94.48"; 118.1"; 157.4"; 196.8"; 236.2"

## Controllers Xtend<sup>3</sup>, Xact & dot board

Xtend<sup>3</sup> is a modular control system that can be configured to meet the specific requirements of all applications. With the option to integrate adhesive monitoring.

Xact is a high performance control system that offers precision and accuracy in adhesive applications. It has a user-friendly interface and can be easily integrated.

The dot board is a compact control system that can be integrated directly into the control cabinet. Incoming PLC signals are used for job control.

## Hot melt units

The hot melt units are combined with Xmelt hot melt hoses and application heads to form a hot melt application system. The central hot melt unit detects all connected assemblies and automatically optimises the system parameters. As a result, you can set up the system more easily, more reliably and faster. The Xmelt fusion hot melt units transform adhesive granules into liquid glue, also regulating the process pressures and temperatures throughout the entire system.



Xmelt fusion melter

## Your benefits with tesla pro

- Electromagnetic hot melt application head for glue dots and beads
- Application frequency: 600 Hz
- 10 times longer service life, compared to electropneumatic hot melt application heads
- Reduction of operating noise by 30 dB – compared to electropneumatic hot melt application heads – to 65 dB
- Cost savings through elimination of the compressed-air supply
- For use with Xmelt hot melt systems with Xpect / VE04 controller
- Max. pressure 80 bar
- Integrated overtemperature cut-out
- Plug-in module
- Thermal insulation
- The nozzle is opened electrically and closed by spring action
- Dot application even at the highest machine speeds
- Excellent cut-off characteristics, even during pro, intermittent gluing
- Compact design
- Multi-application heads also available, due to modular design
- Suitable for adhesives with viscosities up to 5,000 mPa.s
- Less adhesive is required for dot application

## Technical Data

Model	Xmelt fusion 4kg Basic	Xmelt fusion 4kg Basic feeding	Xmelt fusion 8kg Special volume
Melting rate	14 kg/h*	14 kg/h*	14 kg/h*
Performance Data			
Tank	1.6 kw	1.6 kw	1.6 kw
Channel	1.2 kw	1.2 kw	1.2 kw
IP	40/54	40/54	40/54
Electrical connection	3/PE AC 200V -240V ±10% 50/60Hz, 3/N/PE AC 400V ±10% 50/60Hz		
Compressed air	6 bar	6 bar	6 bar
Temperature range	20-200°C	20-200°C	20-200°C
Control accuracy	±0,5°C	±0.5°C	±0.5°C
max. hotmelt pressure	max. 80 bar	max. 80 bar	max. 80 bar
Ambient temperature	0...40°C	0...40°C	0...40°C
Hose connections	2-8	2-8	2-8
Weight	49 kg	52 kg	50 kg
Interfaces	Ethernet IP, Modbus, Xtend <sup>3</sup> , USB. Optional: Ethercat, Profibus, Profi Net, DeviceNet, ControlNet		

\*Dependent on adhesive

