

Side Seam Gluing Solution

hhs
Baumer Group

Replace glue wheel units
with non-contact gluing

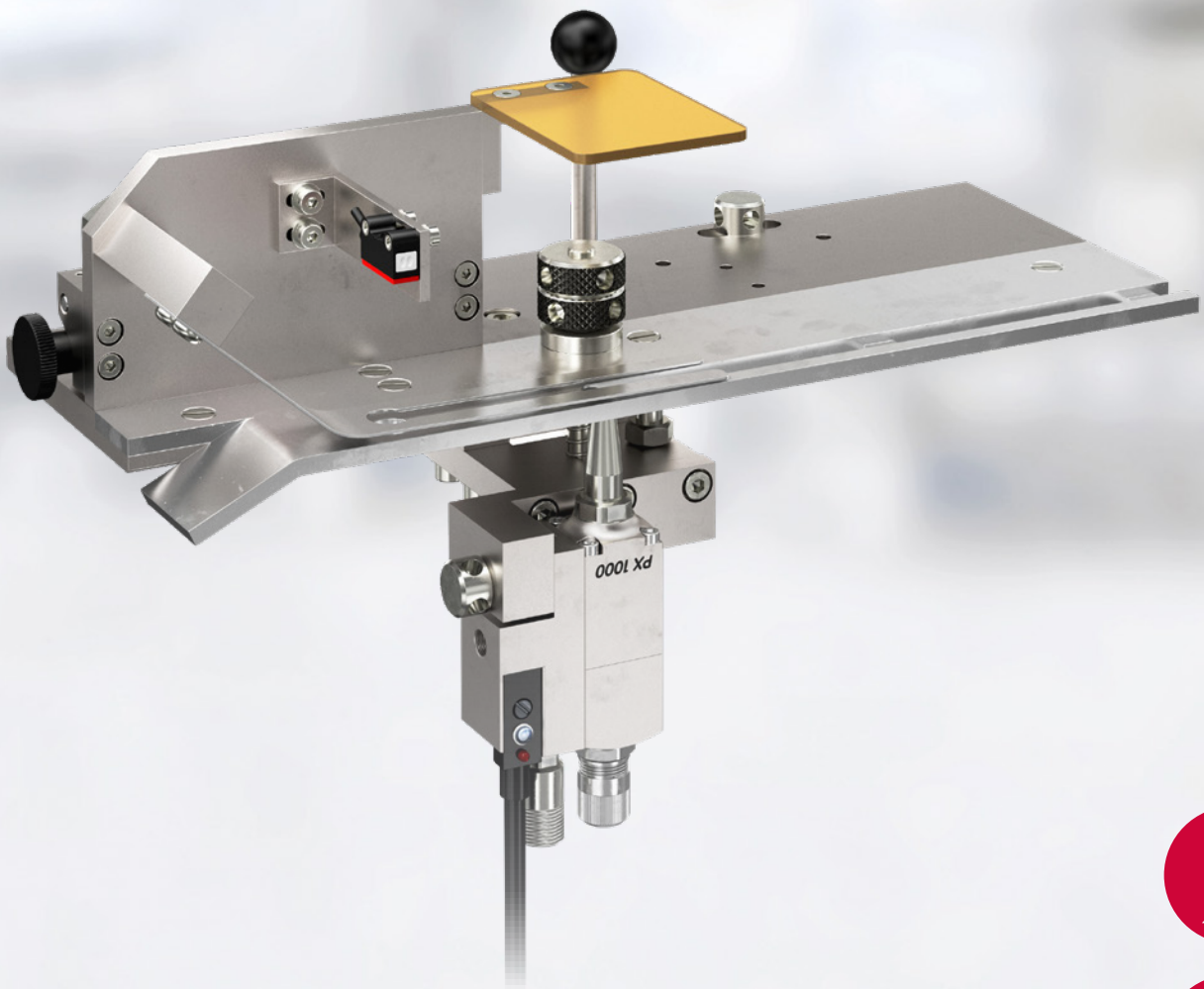

Xcold

Let's stick together



baumerhhs.com

Complete system maximizes production output in side seam gluing

In folding box production, the adhesive traditionally is applied by a glue wheel or disc to bond the side seams. For lack of an alternative, the industry accepted the problems associated with this method, such as cleaning the units and wasting glue. The Side Seam Gluing Solution from Baumer hhs replaces existing glue wheel units and offers many advantages.

Technology

The Side Seam Gluing Solution consists of a gluing nozzle that applies adhesive to glue flaps from below in a non-contact process. The powerful PX 1000 cold glue application head is the heart of this complete system. Its high closing force guarantees perfect gluing and prevents contamination, even when installed this way. The integrated light barrier reliably detects every glue flap and independently controls gluing. Non-contact application offers the option of segmenting the bead of glue. This Glue Save mode makes it possible for the first time in side seam gluing to significantly lower adhesive consumption, cut costs and reduce CO2 emissions.

Integration

The switch to non-contact gluing couldn't be easier. The existing glue wheel unit is removed from the machine and the Side Seam Gluing Solution installed in exactly the same position. The system's integrated product guide smoothly transports folding box blanks at any speed.

The highlights

- Easy to integrate
- Increases production time by up to 200 hours per year
- Maximum productivity
- + 20 million folding boxes/year
- Reduces adhesive consumption by up to 50%
- No set-up time
- No adhesive waste
- Minimises cleaning
- Up to 700 m/min
- Short ROI

How much you can save with the Side Seam Gluing Solution Example

Annual savings on adhesive			
Adhesive costs	Disposed of daily	Production days	Potential savings
2,5 €/l	3l	250	1.875 €

Annual cleaning costs			
Machine hour	Cleaning time/shift	Shifts/day	Production days
250 €	25 min	2	250
			52.000 €

- + Savings on adhesive with stitching mode
- + Higher production output resulting from maximum machine availability

Productivity

Cleaning glue wheels is a very time-consuming task that takes away from valuable production periods. In practice, it takes about 20 minutes per day and shift to clean the wheels and tanks. Assuming two-shift production, this adds up to some 200 hours a year that cannot be used for production – time in which over 20 million folding boxes could be produced. By eliminating cleaning, the Side Seam Gluing Solution supports maximum availability of folder gluers and increases both their output and added value.

Easy operation

The Baumer hhs Side Seam Gluing Solution adheres to the concept of easy operation in side seam gluing. It accurately applies adhesive to within 1 mm on glue flaps from beginning to end, and has settings for adapting both the application quantity and glue pattern. The built-in light barrier reliably detects folding boxes and ensures that adhesive is applied in the pre-defined area. The Xact up controller's Automatic mode eliminates set-up work during job changeovers. Operating staff can concentrate entirely on preparing the machine and on quality.

Sustainable system

This new solution enhances the sustainability of box production. For example, cleaning glue wheel units every day requires large quantities of warm water and the up to 3 litres of glue remaining glue in the glue tanks must be disposed of. What is more, this task may need to be performed more than once per shift depending on the box type and extent of adhesive contamination. The new system eliminates this, saving significant amounts of raw materials and energy.

Reducing glue consumption

Non-contact gluing with the powerful PX 1000 application head now makes it possible to apply short segments or "stitches" of glue, instead of a continuous bead, reducing glue consumption by up to 50%. A push of a button on the Xact up controller is all it takes to reduce the quantity of glue – without compromising adhesive strength in the side seam. In fact, stitching mode considerably increases adhesive strength in most cases.

An investment that pays

Retrofitting the Side Seam Gluing Solution on existing machines pays off in just a short time. It counteracts the current rise in energy and raw material costs in a very simple way and optimises profits by increasing productivity. An investment in the Side Seam Gluing Solution prepares your company to meet future demands.



Save up to 50% on adhesive by switching to stitching mode

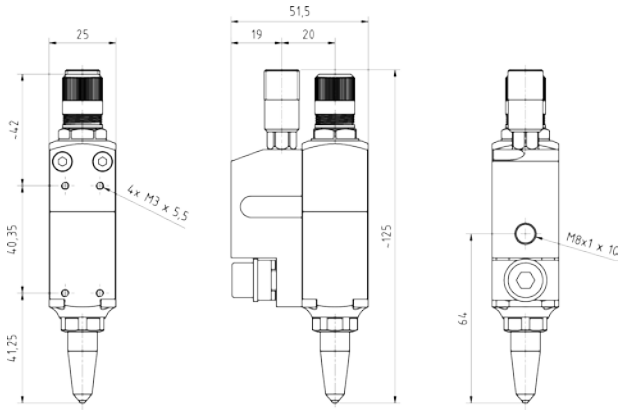

*dimensions in mm

Technical data: PX 1000 application head

Specification	Value
Operating pressure	1,0 – 50,0 bar
Adhesive viscosity, max. (Brookfield)	4000 mPa*s
Possible nozzle diameters	0,3; 0,4; 0,6 mm
Noise emission	<70 dBa
Switching frequency	750 Hz at 20 bar adhesive pressure and 1,000 mPa*s

Technical data: Xact up controller

Specification	Value	Unit
Mains voltage, 1 NPE	115 ± 10 % 230 ± 10 %	V _{AC} V _{AC}
Frequency, maximum	50/60	Hz
Control voltage, signals	24	V _{DC}
Control voltage, application heads	48	V _{DC}
Current consumption at 115 VAC	3	A
Current consumption at 230 VAC	1,5	A
Fuse	3,15	A
Protection class, mains connection	IP32	—
Weight	4,002	kg

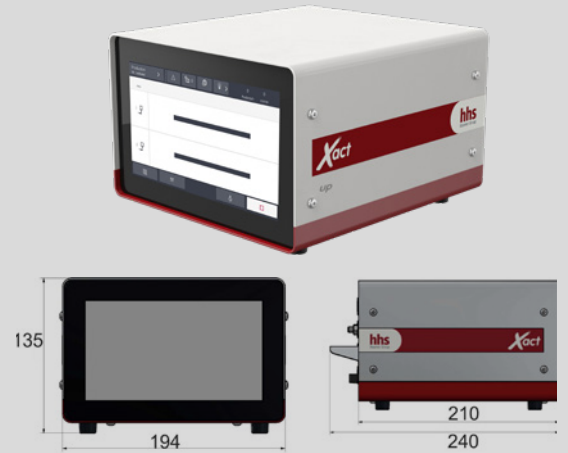

*dimensions in mm

Technical data: DPP 4 glue supply

Specification	Value
Regulated output pressure, max.	20 bar
Inlet air pressure	6-7 bar
Pressure ratio	4:1
Adhesive viscosity	6.000 mPa*s
Delivery rate, max.	2 L/min.
Weight	20,5 kg

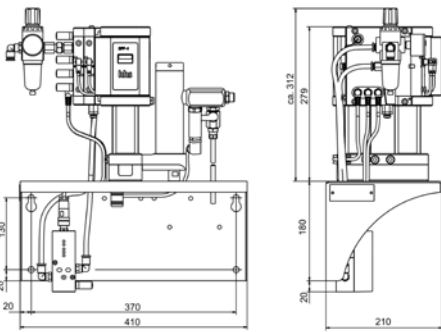

*dimensions in mm

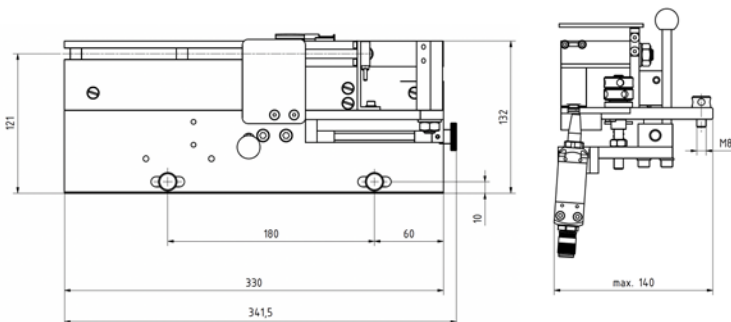

*dimensions in mm



The Side Seam Gluing Solution is easy to install in existing machines.

Baumer hhs – Your competent partner

Baumer hhs, based in Krefeld, Germany, is your worldwide partner for reliable and innovative glue application and quality assurance systems.

For us, quality and precision are basic principles of engineering and manufacturing, and professional services are an integral part of our products. We maintain a constructive and collaborative dialogue with our customers and suppliers, which forms the basis for solutions that optimally meet their individual needs.

Our trained sales staff and technicians support you with any issues you encounter in production. The Baumer hhs solution centre in Krefeld offers you assistance with new applications and in selecting the right adhesives.

We want our customers to be excited – with our premium products and our impeccable all-round service. But it's best to see our products for yourself! Just call or send us an e-mail.

We'd be happy to help you with your next project!



hhs
Baumer Group

Baumer hhs GmbH

Adolf-Dembach-Straße 19 · 47829 Krefeld · Germany
Phone +49 2151 4402-0 · Fax +49 2151 4402-111
info.de@baumerhhs.com · baumerhhs.com