

aerto go

hhs
Baumer Group

The powerhouse for end-of-line packaging.
Pinpoint accuracy even in complex
applications. Save, flexible, durable and
compatible with most hot melt systems



Xmelt

aerto
go

for use with
non-hhs systems

Let's stick together

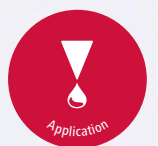

baumerhhs.com

aerto go – The powerhouse

Perfect cut-off, no compromises

Tailings from the hot melt, and the adhesive waste that gets into a packaging machine as a result, won't be your problem any more with the aerto go. This powerhouse from Baumer hhs for direct operation via a programmable logic controller (PLC) meets all requirements that come its way. The extensive variety of domed nozzles makes aerto go the ideal application head for all installation situations encountered in packaging machines. aerto go is compatible with most hot melt systems in the packaging industry. A simple switch eliminates your problems.

Flexible

Every type of job in the packaging industry imposes tremendous demands on the hot melt application equipment. Whether from below, in multiple lines, at great distances or around corners, optimum adhesive application is always a requirement. With the right domed nozzles, the aerto go is the perfect solution.

Strong

The aerto go is the strongest pneumatic hot melt application head in the market. It can apply dots of adhesive even in places where other heads can only achieve lines. With this extremely powerful module, even difficult adhesives can be applied at low temperatures without any tailing and without leaving behind any unwanted material on the product or in the machine.

Innovative and safe

The innovative, novel sealing technology on the aerto head and its quality craftsmanship guarantee high machine availability and a long service life. An overtemperature switch protects both the hot melt unit and application head from exceeding the maximum permissible operating temperature, for comprehensive safety.

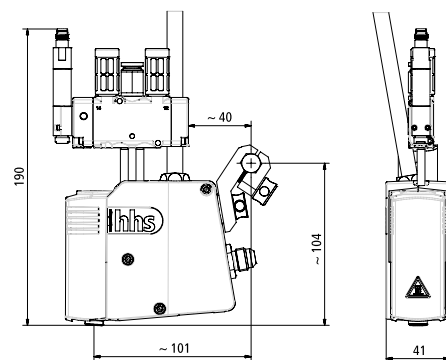

Technical drawing

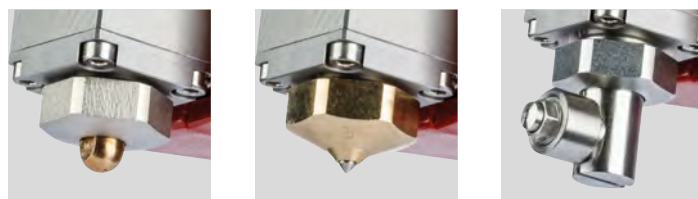

Plug for use with non-hhs systems

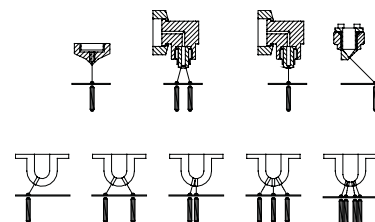

Domed nozzles

Advantages of the aerto go

- For dot and line application
- Powerful module minimises tailing
- Overtemperature switch
- 150 million operating cycles
- Operates with a 24V machine controller
- For adhesives with a viscosity of up to 60,000 mPa.s
- Saves energy thanks to low application temperature and insulation
- Suitable for use with non-hhs systems

Technical data Xmelt aerto go

Parameter	Value
Temperature range	0...200 °C
Operating voltage/ Output	24 Volt / 6 Watt
Temperature monitoring	Ni 120
Cycle frequency*	250 Hz
Connection	Plug for operation with thirdparty systems 3 pin M8
Hose connection	1/2" UNF
Adhesive pressure	80 bar
Adhesive viscosity	max. 60.000 mPa.s
Control air	5.5...6.5 bar, oil-free, dry
Mounting	Via M10x1 thread
Noise level**	82 dB**

*Depends on nozzle size, adhesive and pressure

** With noise protection

hhs
Baumer Group

Baumer hhs GmbH

Adolf-Dembach-Straße 19 · 47829 Krefeld · Germany

Phone +49 2151 4402-0 · Fax +49 2151 4402-111

info.de@baumerhhs.com · baumerhhs.com

 **Carbon neutral**
Print product
ClimatePartner.com/10767-2304-1001